

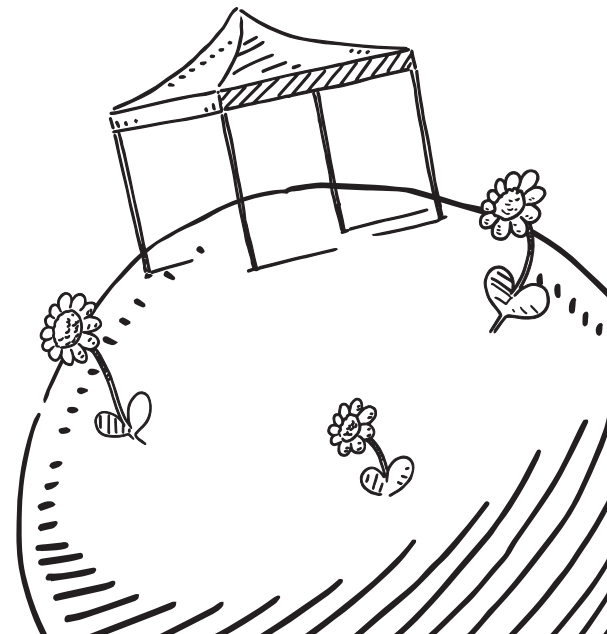

SUSTAINABLE SINCE 1989



LET YOUR TALENTS UNFOLD

In Switzerland, there is a synonym for the word “folding tent”: It’s called “Pro-Tent”. This may be due to the fact that we Swiss have a particular soft spot for products made in Switzerland. Or simply because we invented the aluminium folding tent.



The fact is: For more than 30 years, SMEs, large companies, institutions and associations have relied on Pro-Tent folding tent systems to present themselves professionally at events and trade fairs. In Switzerland, throughout Europe and worldwide.

We firmly believe that the quality and durability of our products are the key to true sustainability. That is what we strive for. Every day, in everything we do.

Our company is based in Rüti near Zurich. From here, our team controls product development, administration and logistics. We are pleased to invite customers and prospects to visit us and experience our folding tent systems hands on in our exhibition area.

Pro-Tent is a leading manufacturer of aluminium folding tent systems – Our path so far:

1989

Heinz Stöckler invents the aluminium folding tent: Easy to transport, quick to set up and fitted with a fabric roof, it is intended for use as a garden tent or beach tent. Until then, similar systems were only made of steel, unwieldy and heavy.

1990

The Pro-Tent folding tent system “Series 1000” sells like hot cakes and soon it becomes clear: The possible applications are almost infinite. Be it car dealerships and hotels, events and weekly markets - the aluminium folding tents are used everywhere.

1995

Imitators enter the market. Even then Pro-Tent is one step ahead of them and launches the Pro-Tent 2000 series, the first modular version of the original idea with extensive accessories.

2000

Until now, the folding tents were marketed under “Stoekler Bio Agrar AG, Division Pro-Tent®”. Now an independent company is created from the already well-known brand - Pro-Tent AG is founded.

2001

The inventive spirit is ever active and the central element of the next Pro-Tent generation is patented in Europe, Asia and the USA: The Omega profile with system slots.

2004

The new system is ready for series production, the Swissmodul 4000 (and today’s Pro-Tent MODUL 4000) conquers the market. The basic idea: All accessories and, for the first time, optional fixed panels are anchored in the slots of the Omega profile. A concept that is worth a gold medal to the jury of experts at the Inventors’ Fair in Geneva and is awarded a special prize for the most innovative invention.



2005

Pro-Tent transfers the complete production of the Pro-Tent MODUL 4000 folding frame to the BSZ Foundation in Einsiedeln. Pro-Tent thus contributes to the integration of handicapped persons and can rely 100 % on “Swissmade” precision work according to DIN EN ISO 9001.

2012

The Bär family takes over Pro-Tent AG, Beat Bär becomes the new CEO.

2015

Expansion of own production and refocusing on Europe as a production location.

2016

Pro-Tent establishes its own branch in Germany with headquarters in Hadamar-Niederzeuzheim, Hessen.

2020

With the Pro-Tent 5000, Pro-Tent presents a new folding tent system for areas of application where special stability is required or desired. The folding frames are manufactured at the BSZ Foundation in Einsiedeln. At the same time, production of the 2000 series is relocated to Einsiedeln, so that all Pro-Tent systems are now manufactured at the BSZ Foundation.



“As an entrepreneur, I firmly believe that we can only be successful in the long term if we live up to our ecological and social responsibilities. We have therefore defined four sustainability principles for ourselves, which form the framework for our strategic goals and our actions. As a family man, I would like to make my contribution to ensuring that the world we live in is also a world worth living in for future generations. There is no Planet B!”

Beat Bär
CEO Pro-Tent AG

OUR SUSTAINABILITY PRINCIPLES:

QUALITY

For us, quality and sustainability go hand in hand. Because the longer the “life” of a product, the fewer resources are consumed. This requires well thought-out design, the use of high-quality and hard-wearing materials and excellent workmanship.

CONTINUITY

The claim to offer a high-quality product and to act in an ecologically and socially responsible manner has accompanied us since our beginnings. We are not guided by short-term trends but by our own convictions and the needs of our customers.

PARTNERSHIP

Our primary goal is not to close the sale per se, but to build a solid, mutually beneficial partnership. This also includes cooperation with our suppliers. Long-term business relationships make us a reliable partner for them.

RESPONSIBILITY

As a company, we bear responsibility and are very aware of this: For the people we work with. For the relationships with our customers, suppliers and business partners. For good cooperation and the common good at our locations. For the environment in which we live.

We support the Global Goals.

In 2015, the United Nations presented 17 sustainable development goals to be achieved by 2030. The goals outline an ambitious global agenda to reduce poverty and hunger, improve health, enable equality, protect the planet and much more. An important vision shared by many governments and companies around the world. We are also committed to all 17 goals and focus on those where we believe we can make the greatest possible contribution.

 <p>1 KEINE ARMUT No poverty</p>	 <p>8 MENSCHENWÜRDIGE ARBEIT UND WIRTSCHAFTS-WACHSTUM Good work and economic growth</p>	 <p>12 NACHHALTIGERE KONSUMTION UND PRODUKTION Sustainable consumption and production</p>
 <p>13 MASSNAHMEN ZUM KLIMASCHUTZ Climate protection measures</p>	 <p>17 PARTNERSCHAFT FÜR ZIELE Partnership to achieve the goals</p>	

Corporate Governance

KEEPING YOUR WORD



OUR MISSION STATEMENT:

CUSTOMER ORIENTATION

The customer is at the centre of everything we do. Our services are permanently oriented towards his needs and requirements.

INNOVATION AND QUALITY

We stay ahead of the competition through innovation and the pursuit of perfection.

DEVELOPMENT

The enthusiasm for the Pro-Tent brand drives us to continuously develop the company and our products.

TEAMWORK AND COMMITMENT

Our work is characterised by mutual respect and appreciation. We contribute to our success through qualification and commitment.

SWISS COMPANY

As a Swiss company, we are committed to Switzerland as the location of our company. In terms of social sustainability, our responsibility is to preserve jobs and thus the financial security of the employees working here.

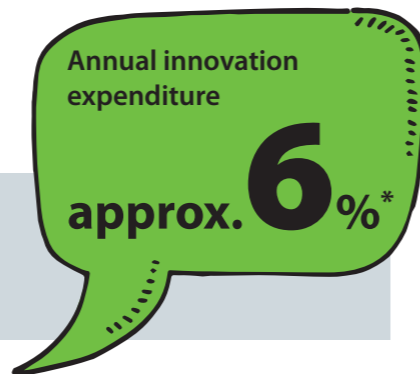

*average share of turnover from 2018 to 2020

The sustainable successful development of our brand is not based on good business results alone. A good reputation and the trust of our customers and business partners are priceless for us. Our actions therefore follow clear moral and ethical principles.

2020 was not an easy year. Not for the event industry as a whole and not for us. Nevertheless, it was important for us to live up to our responsibility as a company even in these difficult economic times – towards our employees, production partners and service providers.

The awarding of contracts to external production partners and service providers was essentially maintained – in line with the operational course of business.

OUR STRATEGIC GOALS UNTIL 2026:

ORGANIC GROWTH

We want to preserve our creative freedom as a company through organic growth and sustainable value enhancement.

AGILITY

We continuously adapt to the developments and necessities of the market both strategically and operationally.

QUALITY LEADERSHIP

We want to continue to be the recognised quality leader in our market segment.

SUSTAINABLE ACTION AND MANAGEMENT

As a company, we are aware of our economic, ecological and social responsibility and act accordingly.

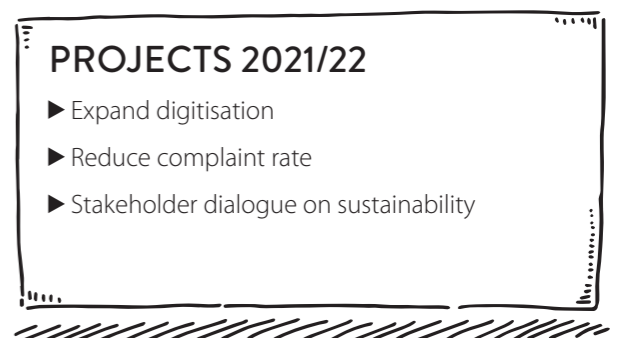

Products

QUALITY IS CENTRAL

Pro-Tent is a brand product. As a manufacturer, we live up to this claim and want to deliver a sustainable product that works perfectly and reliably even after 10 or 15 years of intensive use.

In this context, our high vertical integration with our own product development, manufacturing, sewing and printing is of great benefit. We know who assembles our tent frames, who sews our tent roofs and side walls and who puts the finishing touches to a Pro-Tent with an individual print motif. As one of the few European folding tent manufacturers, we can thus guarantee the quality of our folding tents as well as a responsible production process - in contrast to the many suppliers who only import tents. We source our aluminium profiles, polyester fabrics and accessories from a small circle of selected suppliers. We have been a reliable partner to them for many years and thus create the conditions for good social and working conditions in these companies as well.

A recycled fabric was added to our range for the first time in 2020. During production, PET bottles and used polyester fabrics are not disposed of as waste as usual, but are processed into new yarn in an innovative process. The fabric we use is TESTEX-certified.



INDESTRUCTIBLE SINCE 1995: PRO-TENT 2000

The original and the classic among the aluminium folding tent systems – with more than 50,000 already in use. The well thought-out construction, the low weight and pack size make our Pro-Tent 2000 the first choice for many event professionals to this day.

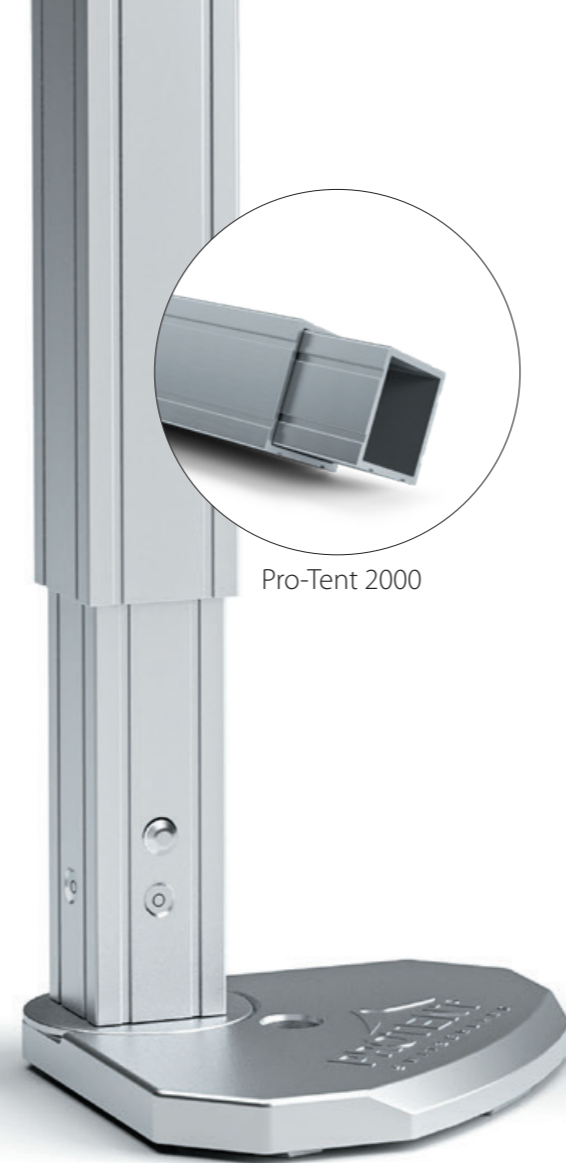

Pro-Tent 2000

FOLDING TENT RETHOUGHT: PRO-TENT MODUL 4000

Ingeniously simple, simply ingenious: The Omega slot of the Pro-Tent MODUL 4000 series is used to accommodate the side walls. Lateral connectors and other accessory elements are fixed in the slots of the profile with quick-release locks. A further unique feature: In the system trade fair stand version, our Pro-Tent MODUL 4000 is also ideally suited for indoor use.



Pro-Tent MODUL 4000

IT DOESN'T GET ANY MORE STABLE THAN THIS: PRO-TENT 5000

In addition to the characteristic Omega profile, our family addition from 2020 boasts an extra-strong profile diameter of 45 mm. Perfect for everyone who relies on maximum stability and therefore particularly suitable for longer standing times.



Pro-Tent 5000

PROJECTS 2021/22

- ▶ Increasing the share of recycled polyester fabrics
- ▶ Reduce resource requirements along the supply chain
- ▶ Develop Pro-Tent "Second Life" Concept

Employees STANDING TOGETHER

“Promote sustained, inclusive and sustainable economic growth, full and productive employment and decent work for all”
is what it says in Goal 8 of the Global Goals.

For us, this means recognising the individuality of each of our employees - with all their strengths and weaknesses. We see equality, diversity, respect and inclusion as an opportunity and want to offer our employees the prerequisites for a fulfilling working life with an open corporate culture.

All employees contribute equally to the success of our company. In purchasing, assembly, sewing and printing, in sales and marketing, in order processing, in accounting and in the warehouse. Finding and retaining qualified and motivated employees therefore remains a central task at Pro-Tent AG.

Total number¹ Employees 2020



60

¹in Pro-Tent Group

Proportion of women/men 2020



Women

52%

Men

48%

Employment 2020



Permanent

100%

Limited

0%

Proportion full-time/part-time



Full-time

96%

Part-time

4%



The BSZ Foundation in Einsiedeln has been part of the big Pro-Tent family since 2005. Here, people with disabilities assemble our tent systems. Manufacturing a premium product that is appreciated worldwide fills the BSZ employees with particular pride.

In the ISO-9001 certified company, individual teams are responsible for different production steps. For example, one team cuts and rounds aluminium profiles, while another drills, mills or cuts the profiles. One group is responsible for oiling and assembling the folding frame, another for the function check and packaging. After

each operation, the workpiece is checked twice by team members and the group leader. While everything has to happen quickly in a purely performance-oriented company, at BSZ they take the necessary time for all work steps. Each aluminium profile is processed with great care, which in turn is reflected in the quality of the products. The cooperation with the BSZ is therefore an enrichment for us in every respect. During regular visits we exchange ideas and also have lots of fun – you can really feel the passion we have for our product.

PROJECTS 2021/22

- ▶ Continue to promote and support the personal development of employees
- ▶ Strengthen employee involvement: Set up an idea box for more sustainability
- ▶ Continue regular exchange with BSZ

Environment

THINKING AHEAD

Climate change affects us all. It doesn't stop at national borders. The effects that are already visible and tangible today are endangering the livelihoods of large sections of the population in less developed regions of the world. Biodiversity is declining worldwide, entire ecosystems are threatened.



As a company, we are part of the problem because of our consumption of natural resources and the CO₂ emissions we cause. We must therefore also be part of the solution and contribute to minimising our ecological footprint by implementing appropriate measures.

Our aim is to continuously advance the ecological orientation of Pro-Tent AG in the coming years and raise awareness of our common responsibility both internally and externally.

Quality and sustainability go hand in hand for us. In this sense, the durability of our products makes a decisive contribution to reducing the consumption of resources and the CO₂ balance of our production cycle. But we want to and can also do more; we firmly believe that every measure - however small - makes an important contribution.



Repairing is more sustainable than buying new products: Contrary to the trend towards ever shorter life cycles of products, our folding tents are designed in such a way that if there is damage, it can also be repaired. In most cases, our systems can be repaired by taking a few simple steps. Our spare parts service, repair instructions for each model and telephone repair support are available for this purpose. A repair kit is available for damaged fabrics, consisting of liquid glue and fabric in the colour of the roof or side wall.



The electricity at our Rüti site comes from renewable sources and is therefore **100% emission-free**.



The production at BSZ Einsiedeln is **100% CO₂-neutral**.



If wood is processed by us, e.g. for the counter top of our bar counter, it is exclusively **FSC-certified wood** from Switzerland.



We prefer to publish our corporate publications in digital form. Printed editions are produced in a **climate-neutral** fashion.

PROJECTS 2021/22

- ▶ Reduction of mobility emissions / purchase of electric vehicles
- ▶ Reduction of upstream transport emissions
- ▶ Conversion of the entire packaging material to recycled qualities or recyclable materials

Society CONTRIBUTE

We love sport: As a company, we see it as our responsibility to make a contribution to society. The connection to sport with its diverse outdoor events and competitions is obvious due to our product orientation.

Sport connects and strengthens our society. It conveys values such as tolerance and fairness, it brings people of different cultures and social backgrounds together. Sport is part of a healthy lifestyle and supports integration and education. Good reasons for us as a brand and a company to identify with sport in all its facets.

Biking, running, swimming, gymnastics, hockey and much more – our commitment includes local and national sponsorship of various sports and events as well as support for clubs and individual athletes with and without handicaps.

It gives us great pleasure to support and accompany them and so we are not only present at the events and competitions as an official tent partner, but can also often be found personally among the spectators.

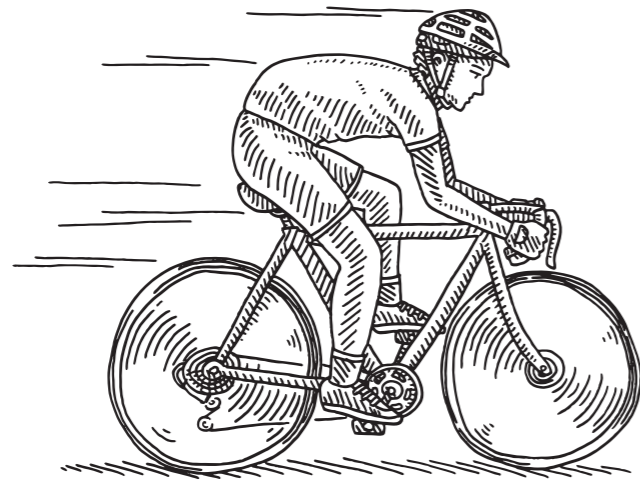

PROJECTS 2021/22

- ▶ Continue sports sponsorship and expand where possible
- ▶ Maintain social and cultural engagement at local level
- ▶ Increase donation volume



Sustainable thinking is proved through action. On both a large and small scale, it is important to keep an eye on the effects on people, society and our environment and to act in a measured and conscious manner.

Our brochure on sustainability was printed in a small edition of 500 copies in a climate-neutral way on FSC-certified paper.

If you would like to learn more about Pro-Tent and our view on sustainability, we would be pleased to answer your questions.

PRO-TENT AG
Zelt- und Messebau-Systeme
Neuhofstrasse 10
8630 Rüti
Switzerland
Tel.: +41 (0) 55 220 28 00
info@pro-tent.ch
www.pro-tent.ch

